AEG SOLAR MODULES

INSTALLATION MANUAL

**GLASS-BACKSHEET (STANDARD)
MODULE SERIES:**

**AS-MXXX2 / AS-MXXX3 / AS-MXXX7-S /
AS-MXXX8 / AS-PXXX8 / AS-MXXX9 / AS-PXXX9**

AEG

AEG GLASS-BACKSHEET (STANDARD) SOLAR MODULES INSTALLATION MANUAL

Thank you for choosing the reliability of AEG solar modules.

This installation manual is intended for dealers and installers involved in the planning, installation and commissioning of photovoltaic systems deploying AEG solar modules. These instructions provide you with valuable information to ensure that your PV installation runs smoothly and achieves optimal yields over its whole lifecycle.

AEG solar modules are tested and approved by acknowledged independent certification authorities and can only be installed by qualified professional companies.

Please observe the standards and regulations applying to photovoltaic systems in the relevant countries, as well as the rules of the employers' liability insurance associations for accident protection. Failure to comply with these can result in major injuries and damage.

Keep this guide in a safe place for further reference as it contains important information for product care, maintenance and disposal.



CONTENTS

1.1 Icons	2
1.2 Product Identification	3
2. Safety	3
2.1 General safety	3
2.2 Handling safety	3
2.3 Installation safety	4
2.4 Fire safety	5
3.1 General remarks	5
3.2 Mechanical installation	5
3.2.1 Bolting	6
3.2.2 Clamping	6
3.2.3 Insertion systems	7
3.2.4 Loading capacity	7
3.3 Electrical Installation and Grounding	8
3.3.1 General remarks	8
3.3.2 Electrical installation	8
3.3.3 Grounding	9
4. Maintenance	10
4.1 General maintenance	10
4.2 Cleaning	10
4.3 Module End of Life	10
5. Disclaimer of Liability	11
6. Contact	11

1. PRELIMINARY REMARKS

1.1 Icons

This section describes relevant warning symbols recurring in the installation and operation manual of AEG solar modules. Icons highlight relevant information for the physical and property safety of the user. Compliance to the provided instructions is essential to prevent physical injury and product damage. Below is a list of the icons used in this manual:

Icon	Meaning	Instruction
	Danger	Serious physical injury or even death may occur in case of noncompliance with the requirement (electrical hazard)
	Warning	Physical injury or product damage may occur in case of noncompliance with the requirement.



Icon	Meaning	Instruction
	Prohibited	Damage may occur in case of noncompliance with the requirement.
	Note	Useful information for product maintenance and operation is provided

Table 1: Icon meaning

1.2 Product Identification

Each module can be identified by means of the following information:

Product Label

It is placed on the module backside. According to EN 50380 Directives it provides information about the main parameters of the module: Product Type, Maximum Power, Current at Maximum Power, Voltage at Maximum power, Open Circuit Voltage, Short Circuit Current -as measured under Standard Test Conditions, Maximum System Voltage, Maximum Series Fuse etc. The product label also features the Product Name Code (PNC).

AEG		MONOCRYSTALLINE PHOTOVOLTAIC MODULE
Module Type	AS-M1202-H(G1)-340	Measured at Standard Test Conditions (STC) 1000 W/m ² , T _c =25°C, AM=1.5 For field connection please use minimum Ø 4mm ² (12 AWG) copper wires insulated for a maximum temp. 90°C.
Maximum Power (P _{max})	340 W	
Power Sorting	0 - 5 W	Tested according to IEC 61215-1:2016, IEC 61730-1:2016, IEC 61215-2:2016, IEC 61730-2:2016.
Open Circuit Voltage (V _{OC})	41.70 V	
Short Circuit Current (I _{SC})	10.40 A	This photovoltaic module produces electricity when exposed to light. Please refer to the instructions stated in the mounting manual for proper use.
Maximum Power Voltage (V _{mp})	34.01 V	
Maximum Power Current (I _{mp})	10.01 A	 Hazardous electricity can shock, burn or cause death. Do not touch connectors!
Maximum System Voltage	1000 V	
Maximum Series Fuse	20 A	
 PV Module classification Class II	Tolerance on P _{max} : ±3% Tolerance on V _{OC} : ±3% Tolerance on I _{SC} : ±4%	
Solar Solutions GmbH Brückenstrasse 9A 60594 Frankfurt am Main Deutschland / Germany www.aeg-industrialsolar.de +49 (0)69 40030080 Product assembled in People's Republic of China AEG is a registered trademark used under license from AB Electrolux (publ).		

Figure 1: label example

Serial Number

Each individual module is identified by a unique serial number univocally coupled with a barcode. Serial number and barcode are permanently placed on the laminate, under the front glass of the module, and are visible from the module front.

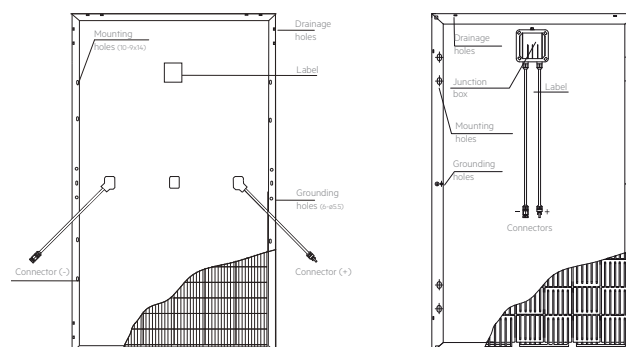

Figure 2: Examples of product technical drawings

Please refer to the specific product datasheet on www.aeg-industrialsolar.de for the latest technical data.

2. SAFETY

2.1 General safety

All AEG PV modules should be installed according to all local and national applicable standards, codes and regulations. Only qualified personnel should install the solar modules. Installers bear the risk of all injury that might occur during installation including, without limitation, the risk of electric shock. Check and follow all safety precautions specified even for the other components of the system.

Look for any visible damage to the package or the product itself. Double-check the order information and the product nameplate to ensure the products are of the ordered type. Should you find any problems, contact the shipping company and / or your supplier as soon as possible before attempting product installation.

2.2 Handling safety

Please observe the below indications when handling AEG solar modules:

Store the pallets in a ventilated, dry location until installation. Do not open the module boxes during storage or transportation. Inappropriate transport and installation may void the warranty.



Do not apply paint or adhesive to module top surface.

Do not use mirrors or other magnifiers to artificially concentrate sunlight on the modules. Do not expose back sheet foils directly to sunlight. Do not attempt to disassemble the modules. Do not remove any attached nameplates or components.

Do not exceed the maximum stapling limitation of 2 pallets (standard packaging for shipment).
 After unpacking, the modules should be laid horizontally. Do not incline or stack the modules.
 Do not pile up modules without protections to prevent scratches to the glass and frame. Should the modules need to be piled, they need to be separated by special paper or plastic angles.
 Do not scratch or damage the module surface.
 Do not drill holes in the frame as it may compromise its strength, cause corrosion and void the warranty.
 Do not use the junction box and cables as a grip.
 Do not drop the module or allow objects to fall on the module.
 Do not place any heavy objects on the module to avoid glass breakage.
 Do not stand or step on the module.
 Do not set the module down hard on a surface.



Do not attempt to repair a module with broken glass or torn backsheet and do not use it as contact with any module surface or the frame could cause an electric shock.

2.3 Installation safety

Installing solar photovoltaic systems requires specialized skills and knowledge. Photovoltaic solar modules are designed for outdoor use, and may be ground mounted as well as mounted on rooftops, vehicles or boats. The proper design of support structures is a responsibility of the system designer and installer. When installing the system, abide with all local, regional and national statutory regulations. Keep children away from the installation site and during transportation and installation of the electrical equipment.

Cover the module completely with a dark opaque material during installation to prevent electricity generation.

When working with modules without any cover, the safety regulations for live electrical equipment need to be followed. Use only equipment, connectors, wiring and support frames suitable for use in a solar electric installation.



Do not wear metallic rings, watchbands, ear, nose or lip rings or other metallic devices while installing or troubleshooting photovoltaic systems in order to avoid electric shock.
 Do not disconnect modules under load to avoid electrical arcs.

Contact with electrically active parts of the modules, such as terminals, can result in burns, sparks and lethal shock whether or not the module is connected. Do not insert electrically conductive parts into the plugs and sockets.

Do not install solar modules and wiring with wet plugs and sockets.

Exert extreme caution when carrying out any work on the wiring. High contact voltages can generate in the inverter when it is isolated.

Abide with the safety regulations for all the other components used in the PV system, including wiring and cables, connectors, charging regulators, inverters, storage batteries and rechargeable batteries, etc



One individual module may generate DC voltages greater than 30 V when exposed to light of any intensity. Contact with a DC voltage of 30 V or more is potentially hazardous. The series or parallel connection of the modules increases the voltage or electric current respectively. The electrical characteristics are within the following tolerances of the indicated values of I_{sc} , V_{oc} and P_{mpp} under standard test conditions (irradiance of 1000 W/m², AM 1.5 spectrum, and a cell temperature of 25 °C/77 °F) :

Model	Tolerance
AS-Mxxx2	$I_{sc} \pm 4\%$ $V_{oc} \pm 3\%$ $P_{mpp} \pm 3\%$
AS-Mxxx3	$I_{sc} \pm 5\%$ $V_{oc} \pm 3\%$ $P_{mpp} \pm 3\%$
AS-Mxxx8 / AS-Pxxx8	$I_{sc} \pm 5\%$ $V_{oc} \pm 5\%$ $P_{mpp} \pm 5\%$
AS-Mxxx7-S / AS-Mxxx9 / AS-Pxxx9	$I_{sc} \pm 3\%$ $V_{oc} \pm 3\%$ $P_{mpp} \pm 3\%$

Under normal conditions, a photovoltaic module is likely to experience conditions that produce more current and/or voltage than reported at standard test conditions. Accordingly, the values of I_{sc} and V_{oc} marked on the module should be multiplied by a factor of 1.25 when determining component voltage ratings, conductor current ratings, minimum factor of fuse sizes, and size of controls connected to the PV output.

The maximum reverse current is:

Model	Max.Reverse Current
AS-Mxxx2	20 A
AS-Mxxx3	20 A
AS-Mxxx8 / AS-Pxxx8	20 A
AS-Mxxx7-S / AS-MXXX9 / AS-Pxxx9	15 A

2.4 Fire safety

AEG PV modules are tested according to the provisions of IEC EN 61730 Directive with Application Class A. Fire safety has been rated as Class C.



Please be aware that rooftop installations can affect the fire safety of a building. Rooftop installations should be placed over fire resistant roofs only; fire class A is recommended. Only fire-resistant components should be used for rooftop installations.

Do not install the solar panels in the proximity of sources of flammable gases and vapors or open flames.

3. INSTALLATION

3.1 General remarks

AEG PV modules should be installed in a location where they can receive the maximum amount of sunlight throughout the year. In the Northern Hemisphere modules should face south, while in the Southern Hemisphere they should face north. The modules should not be shaded at any time by trees, antennas, cables, houses etc. If a module is shaded or even partially shaded, it will fail to perform at ideal conditions and this will result in lower power outputs.

AEG PV modules connected in series should be installed at the same orientation and tilt angle. Different orientations or angles may cause a loss of power output due to the change in sunlight exposure. Dust building up on the surface of the modules can impair module performance. Solar Solutions recommends installing the modules with a tilt angle of at least 10 degrees, making it easier for dust to be washed off by rain. When designing the final layout of the modules in a photovoltaic system, keep suitable access space to

allow easy maintenance and inspection works. Provide adequate ventilation under the modules for cooling.

Always use structures and materials specifically developed and certified for photovoltaic module installation.

AEG PV modules must be installed and stored in the following conditions:

Operating temperature	From -40°C to +85°C
Extreme weather cond.	From -30°C to +50°C
Storage temperature	Up to 30°C
Humidity	Below 85% R.H.



Do not carry out the installation in high winds and prevent the falling of objects from the roof. Secure the work area so that nobody on or beneath the roof can be injured.

When installing a module on a roof or building, please ensure that it is securely fastened and cannot fall as a result of wind or snow loads.

The modules should not be immersed in liquid. Corrosion risk incurs if the module is exposed to salt (i.e. marine environments) or sulfur sources. The installation distance of the modules to sea water or lakes should therefore be at least 500 m unless otherwise specified. The module should not be exposed to unusual chemical loads. For fire safety indications, please see 2.4 “Fire safety”.

Protect the solar modules from overvoltage, e.g. voltage peaks of battery charges, generators, etc. If the module has to be connected to a storage battery, all precautions as prescribed by the battery manufacturer should be taken into account

3.2 Mechanical installation

AEG PV modules can be installed in either landscape or portrait orientation. Please consider the details for individual module types as laid out in the next paragraphs. In choosing the orientation, please keep in mind the internal PV module bypass diode configuration to ensure the optimum electrical behavior from any potential shading over the module. Ensure modules are not subjected to wind or snow loads

exceeding the maximum permissible loads, and are not subject to excessive forces due to the thermal expansion of the support structures. Ensure that the drainage holes of the PV module do not incur in blockage. Do not dismount, drill or modify the frame or any other part of the PV module, as this will void the warranty. Please contact our Technical Service should you need any clarification concerning the installation instructions.

If the modules are unpacked but not installed immediately, please wrap the connectors to prevent damage caused by wind or rain. Do not use any lubricant on connectors and do not remove the waterproof rubber rings from the junction box or connectors.

The module mounting structure must be made of durable, corrosion-resistant and UV-resistant material. A tested and certified mounting structure approved for the considered system design should be used. Ensure the installation method and mounting structure are able to withstand the load conditions. Always observe the instructions and safety precautions of the mounting structure. In regions with heavy snowfall in winter, select the height of the mounting structure so that the lowest edge of the module is not covered by snow at all times. In addition, ensure that the lowest portion of the module is high enough not to be shaded by plants, trees or dirtied by soil.

Modules must be securely attached to the mounting structure. For clamping system installation, follow the instructions provided by the clamping system supplier.



Avoid exposing the frame to lateral tension and pressure, as this might crush the glass or spark a fire. Consider the linear thermal expansion of the frames: the recommended minimum distance between two modules is 1 cm.

For ground-mounted systems, the minimum distance recommended from the ground to the module bottom is at least 60 cm (24 inches).

For roof-mounted systems, always ensure the suitability of the roof construction before installing the modules on a roof. In addition, any point of roof penetration required to mount the modules must be properly sealed to prevent leaks.

Provide adequate ventilation under the modules in

conformity to local regulations. A minimum distance of 10 cm between the roof plane and the frame of the module is generally recommended. Never allow modules to overlap or to exceed the rooftop size.

AEG PV modules can be installed with:

- frame mounting holes and bolts – See 3.2.1 “Bolting”
- pressure clamps – See 3.2.2 “Clamping”
- insertion systems - See 3.2.3 „Insertion systems“

3.2.1 Bolting

Always observe the instructions and safety precautions of the mounting system. Modules must be securely fixed to the mounting system (support rails) using the provided mounting holes. There are 4 (four) mounting holes placed to optimize the load handling capability of the module and to secure it to the supporting structure. If increased wind or snow-loads are expected, the additional mounting holes provided should be used. It is recommended to use corrosion proof (stainless steel) hardware. Stainless steel M6 bolts (for 11,5 mm holes) / M8 bolts (for 14 mm holes) and a tightening torque between 8-12 N • m (for M6 bolts) and 16-23 N • m (for M8 bolts) are suggested. Please check with your system designer or installer the specific load calculations for your plant; refer to figure 3, figure 5 and to paragraph 3.2.4 „Loading capacity“ for details.

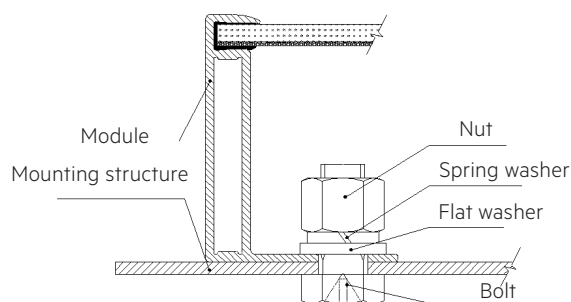

Figure 3: Bolting

3.2.2 Clamping

Installation using pressure clamps can be done on both sides of the module frame. Use at least 4 (four) clamps per module, two on each long side of the module (for portrait orientation) or two on each short side of the module (for landscape orientation). Depending on the local wind and snow situation, additional clamps might be required to ensure the module is able to withstand the load. Module clamps should not come into contact with the front glass and should not deform the frame.

Ensure to avoid shadowing from module clamps. Please refer to figure 4 and figure 6, and paragraph 3.2.4 „Loading capacity“ for details on the individual product series.

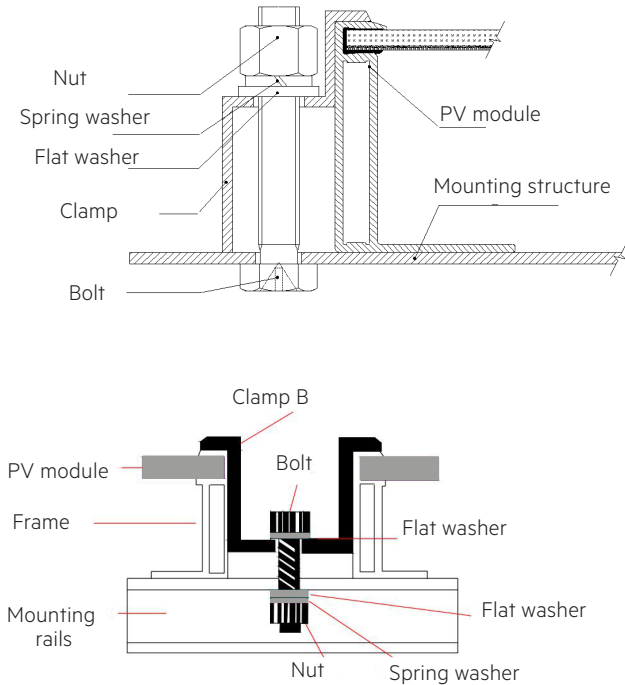

Figure 4: Clamping

3.2.3 Insertion systems

AEG solar modules are compatible with the insertion systems of selected manufacturers. For more information, and for a compatibility assessment of the insertion system you wish to use, contact the AEG service team (see Section 6 „Contact“).

3.2.4 Loading capacity

The PV module’s load resistance is rated as:
 Wind load: 2400 Pa / Snow load: 5400 Pa.
 Please note this could vary according to the different mounting systems and configurations.

For standard conditions, low loading capacity applies:
 AEG modules are tested under a maximum positive pressure of 2400 Pa, and negative pressure of 2400 Pa.

For extreme conditions (e.g.: heavy snow), high loading capacity applies:
 AEG modules are tested under a maximum positive pressure of 5400 Pa, and negative pressure of 2400 Pa.

Please note the indications in the below pictures:
 L=module length (module long side)
 W=module width (module short side)
 X, Y=clamp installation point/ ↑ (arrows) bolting/clamping points

Mounting with bolts	
Module series: AS-Mxxx2, AS-Mxxx9, AS-Pxxx9	Module series: AS-Mxxx2, AS-Mxxx8, AS-Pxxx8, AS-Mxxx9, AS-Pxxx9
Load: positive 2400Pa negative 2400 Pa	Load positive 5400 Pa negative 2400 Pa
Module series: AS-M1203 (G1), AS-M1203 (M6), AS-M3607-S (G1)	Module series: AS-M1443 (G1), AS-M1443 (M6)
Load: positive 5400Pa negative 2400 Pa	Load positive 5400 Pa negative 2400 Pa
Module series: AS-M1443 (G1), AS-M1443 (M6)	Module series: AS-M4327-S(G1) AS-M4327-S(G1)*
Load: positive 2400Pa negative 2400 Pa	Load: positive 5400Pa negative 2400 Pa * =add in case of extreme environmental conditions
Module series: AS-M1443 (G1)	Module series: AS-M1443 (M6)
(Pitch bolt) Load: positive 2400Pa negative 2400 Pa	(Pitch bolt) Load: positive 2400Pa negative 1700 Pa

Figure 5: Bolting, loading capacity scheme

Mounting with clamps (module long side)	
Module series: AS-Mxxx2, AS-Mxxx3 AS-Mxxx8, AS-Pxxx8 AS-Mxxx9, AS-Pxxx9	
Load positive 5400 Pa negative 2400 Pa	
Allowed assembly with clamp $X=1/4 L \pm 50 \text{ mm}$	
	
Module series AS-M4327-S (G1)	Module series AS-M3607-S (G1)
Load positive 5400 Pa negative 2400 Pa	Load positive 5400 Pa negative 2400 Pa
Allowed assembly with clamp $Y=1/2 L$; $X=1/5 L \pm 50 \text{ mm}$	Allowed assembly with clamp $X=1/5 L \pm 50 \text{ mm}$
	

Figure 6A: Clamping on the long side, Loading capacity scheme

Mounting with clamps (module short side)	
Module series: AS-Mxxx2, AS-Mxxx9, AS-Pxxx9	Module series: AS-Mxxx2, AS-M608, AS-P608 AS-Mxxx9, AS-Pxxx9
Load: positive 1600Pa/ negative 1600 Pa	Load positive 5400 Pa negative 2400 Pa
Allowed assembly with clamp $X=1/4 W \pm 50 \text{ mm}$	Allowed assembly with clamp $X=1/4 W \pm 50 \text{ mm}$, $Y=1/2 L \pm 50 \text{ mm}$
	

Module series: AS-M1203 (G1)	Module series: AS-M1203 (M6)
Load: positive 2400Pa/ negative 2400 Pa	Load: positive 1800Pa/ negative 1800 Pa
Allowed assembly with clamp $X=1/4 W \pm 50 \text{ mm}$	Allowed assembly with clamp $X=1/4 W \pm 50 \text{ mm}$
	

Figure 6B: Clamping on the short side, loading capacity scheme

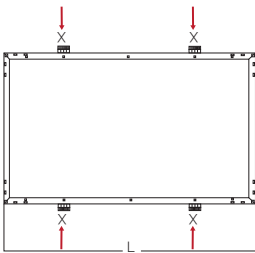
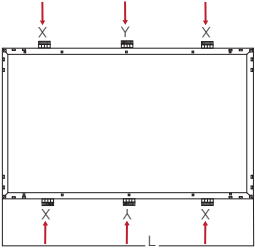
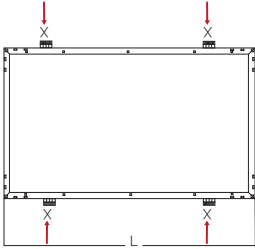
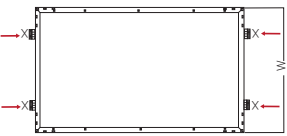
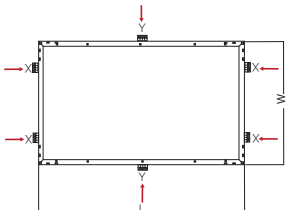
3.3 Electrical Installation and Grounding

3.3.1 General remarks

Modules electrically connected together in a series/parallel configuration generate DC electrical energy, which can be converted to AC by mean of a solar inverter. When modules are connected in series, the total voltage is equal to the sum of individual voltages. For applications requiring high currents, photovoltaic modules can be connected in parallel; the total current is equal to the sum of individual currents.

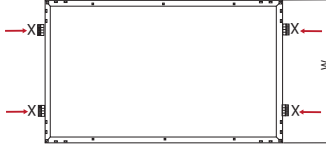
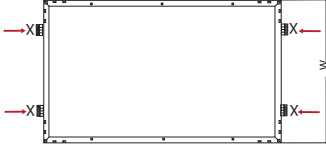
The resulting PV system can then be connected to the local utility grid system. As the policies of local utilities and technical rules concerning the connection of renewable energy systems to power grids vary from region to region, please consult a qualified system designer or integrator to design a system compliant with the related directives. Permits are normally required for installing a PV system and the utility must formally approve and inspect the system before its connection to the grid can be accepted. The connection of the inverter to the grid needs to be done by a competent, authorized company. The electrical installation of the PV system must be carried out in accordance with the respective National Electrical Codes or applicable National Regulations.

3.3.2 Electrical installation

To avoid mismatch, power loss or damage to the PV system, do not use different module types within the same circuit.

The modules are fitted with two pre-assembled sunlight resistant, isolated cable leads, which end with PV fast connectors for the electrical connection of the system (positive [+] and negative [-] terminals). Connectors are Multi-Contact (MC4) or Multi-Contact compatible (MC4-compatible). Cables and connectors must not be removed or cut off.

i Refer to the electrical parameters reported on the label of the module when selecting the size of the cables connecting the module strings to the solar inverter. For electrical design considerations, when determining component voltage ratings, conductor current ratings, fuse sizes and the rest of electrical hardware connected to the module strings, the values provided on the module label or on the related datasheet should be multiplied by a factor of 1.25 for Short Circuit Current (I_{sc}) and Open Circuit Voltage (V_{oc}).

Please consult rated local wiring regulations to determine system wire size, type, and temperature rating of conductors to be connected to module connectors.

The maximum system voltage is 1000 volts or 1500 volts depending on the product type. Please check the product label and datasheet accordingly.

The maximum number of series connected modules depends on system design, the type of inverter used and environmental conditions. Always ensure that the modules are assembled with the appropriate string fuse for circuit protection based on the maximum series fuse rating of the module and local electrical installation codes.

There is no specific limitation on the number of modules that can be connected in parallel; the number of modules is determined by system design parameters such as current or power output.

To prevent the cables and the connectors from overheating, the cross section of the cables and the capacity of the connectors must be selected to suit the maximum system short circuit current. The recommended PV wire should have a cross section of minimum 4mm^2 .

3.3.3 Grounding

Please refer to the respective National Electrical Code requirements and standards for safety-related grounding of racking system and/or module frames. AEG PV Modules use an anodic oxidized aluminum frame; modules should hence be connected to the equipment grounding conductor to prevent electrical shock.

⚡ The frame rails have pre-drilled holes marked with a grounding sign. The grounding holes should be used for grounding purposes only and not for module mounting.

Grounding methods:

Use stainless steel bolt and washer to bond the ground wire and aluminum frame through the grounding hole (see figure 7A and 7B). Please consider the below bolt types and tightening torques:

Series	Bolts/Nuts	Torque
AS-Mxxx2	M8	3-7 N•m
AS-Mxxx3	M5	2.1 ± 0.2 N•m
AS-Mxxx7-S	M4	4 N•m
AS-Mxxx8 / AS-Pxxx8	M4	8.5-12.5 N•m
AS-Mxxx9 / AS-Pxxx9	M3	2.3 N•m

It is recommended to use a $4\text{-}14\text{ mm}^2$ (AWG 6-12) exposed copper wire as ground wire.

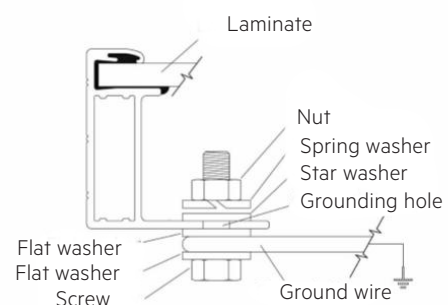

Fig. 7A Grounding method with bolt and washer

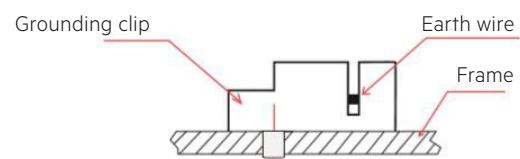

Fig. 7B Grounding Clip

Additional third-party grounding devices: AEG solar modules can be grounded using third-party grounding devices. It is required that these devices are certified for grounding solar modules and are installed according to the manufacturer's instructions.

4. MAINTENANCE

4.1 General maintenance

If any problem arises, have them investigated by a competent specialist; repairing works must be performed by specialized and properly trained personnel only. Improper maintenance can cause lethal electric shock and/or burns.



Use appropriate safety equipment (insulated tools, insulating gloves, etc.) when handling modules.

For any electrical maintenance, the PV system must be shut down first.

Do not touch live parts or cables and connectors.

Do not disconnect the grounding when doing system maintenance works.



We recommend the following maintenance in order to ensure an optimum performance of the module:

Check the electrical and mechanical connections every six months to verify that they are clean, secure and undamaged.

Check that mounting hardware, terminal screws and grounding components are tightly secured and are not affected by corrosion.

Replacement modules must be of the same type of those to be replaced.

Modules generate high voltage when exposed to sunlight. Cover the front surface of modules with an opaque and not scratching material during maintenance.

Follow the maintenance instructions for all components used in the system, such as support frames, charge regulators, inverters, batteries etc.

4.2 Cleaning



Do not clean modules with broken glass or exposed wiring. This can cause a general electrical failure of the module or electrical shock hazard.

Dirt and dust can accumulate on the glass surface of the PV module over time, particularly in installations with low inclination. This can cause a general decrease of power output and also sedimentation on the lower edge of the modules due to dirt accumulation. We recommend a periodic cleaning of PV modules to ensure maximum power output, especially in regions with high quantity of dust in the air or low precipitations as follows:

Under most weather conditions, normal rainfall is enough to keep the PV module glass surface clean. Clean the glass surface of the module as necessary and consider that lower inclination requires higher cleaning frequency.

Always use water and a soft sponge or cloth for cleaning. A mild, non-abrasive cleaning agent can be used to remove stubborn dirt. High mineral content water is not recommended, as it may leave residual deposits on the module.

To avoid a possible thermal shock clean the modules during early morning, when the module is still cold. This is especially recommended in regions with hotter temperatures.

In cold environments with snow do not try to remove the frozen snow or ice from the module scratching on the front glass. Only soft snow can be removed gently with a soft brush.

Do not use abrasive sponges or aggressive tools that could scratch the module surface; under no circumstance should the dirt be dry removed, as this would cause micro-scratches which could have a negative impact on the module's performances.

4.3 Module End of Life

Please return any electrical equipment that you no longer use to the collection points provided for their disposal. Information concerning where the equipment can be disposed of can be obtained from your local authorities.



The wheeled bin symbol on the AEG product labels means that the equipment shall be disposed of as special waste in accordance to the local regulations.

5. DISCLAIMER OF LIABILITY

The use of this manual and the conditions or methods of installation, operation, use and maintenance of the product are beyond Solar Solutions's control. Solar Solutions expressly disclaims liability for loss, damage, or expense arising out of or in any way connected with such installation, operation, use or maintenance.

No responsibility is assumed by Solar Solutions GmbH for any infringement of patents or other rights of third parties, which may result from use of the PV product.

No license is granted by implication or otherwise under any patent or patent rights.

6. CONTACT

Solar Solutions GmbH
Brückenstrasse 94
60594 Frankfurt am Main, Germany
www.aeg-industrialsolar.de
Mail: service@aeg-industrialsolar.de
Tel: +49 (0)69400500810

AEG is a registered trademark used under license from AB Electrolux (publ).