

AEG

IMM TECHNOLOGY



AEG IMM SYSTEM INSTALLATION MANUAL (GATEWAY **S** | GATEWAY **L**)

PD201906 AEG IMM SYSTEM INSTALLATION MANUAL V:1-19 (REF. 2-2) EN

AEG IMM SYSTEM INSTALLATION MANUAL

For AEG IMM Gateway S and AEG IMM Gateway L

Thank you for choosing the reliability of AEG solar solutions!

Gain full insight into the performances of each individual module and take control of your solar installation with AEG IMM (Individual Module Monitoring).

IMM is a unique solar plant monitoring technology at module level for smart plant management run by artificial intelligence.

IMM Technology provides solar plants with the capability of performing advanced monitoring at individual module level. It collects real-life, real-time data from every single module and conveys it to IMM's Web Portal which is capable of precisely locating and recognizing the individual technical issues experienced by the modules. IMM evaluates the necessity and benefits of a maintenance intervention, thus allowing prompt corrective actions and helping plant owners gain full control of their solar plant. IMM Technology runs on Sunsniffer® systems.

1

Please follow the below instructions to successfully set up your Individual Module Monitoring system and start monitoring your solar power plant in real time.

Foreword	5	
How IMM Works	5	
Installation workflow.....	6	
What will I need?	7	
1. Hardware Installation	7	
1.1 IMM System Components.....	7	
1.1.1 The IMM Sensor.....	7	
1.1.2 AEG IMM String Reader	9	
1.1.3 AEG IMM Gateway (S or L).....	9	
1.2. Connection Overview	10	
1.3. String Reader Installation	11	
1.3.1. String Reader Ports and Connections	11	
1.3.2. String Reader LED Indications	11	
1.3.3. String Reader Installation.....	12	
1.3.4. RJ45 Connector Wiring Sequence	13	
1.4. Gateway	14	2
1.4.1. Gateway Ports.....	14	
1.4.2. Gateway LED status and indication	15	
1.4.3. Gateway installation	15	
2.Configuration	16	
2.1. Gateway’s webUI.....	16	
2.1.1. Accessing the Gateway’s webUI.....	17	
2.2. Network Connection.....	18	
2.3. Devices	18	
2.4. Push Service.....	19	
2.5. System.....	20	
3. Preparation for Plant Creation	22	
3.1. PlantView.....	23	
3.1.1. Module Scan	23	
3.1.2. Scan order	23	
3.1.3. PlantView Preparation from Module Scans.....	26	

3.2. Hardware Plan	27
3.3. Module Mapping	27
3.4. Retrofit Mapping	28
4. Plant Creation	28
5. Contacts	28
6. Appendices	29
Barcode sheet for module scan.....	29
Templates / Annexes	30
A1 Template to record the plant properties.....	30
A2 String/String Reader/Inverter assignment sheet (Hardware Plan).....	31
A3 String Reader – Module Mapping.....	32
A4 PlantView Example.....	33
A5 Retrofit box / Module Mapping (Retrofit Mapping).....	34
Checklists.....	35
Checklist for the installation process	35
Checklist to close the hardware installation.....	35

List of Figures

<i>Figure 1: Sensor.....</i>	<i>7</i>
<i>Figure 2: Connecting an IMM-Upgrade to a module</i>	<i>8</i>
<i>Figure 3: AEG IMM String Reader</i>	<i>9</i>
<i>Figure 4: AEG IMM Gateway.....</i>	<i>9</i>
<i>Figure 5: Schematic representation of the AEG IMM Monitoring System</i>	<i>10</i>
<i>Figure 5: Schematic representation of the IMM Monitoring System</i>	<i>11</i>
<i>Figure 11: Gateway’s webUI page.....</i>	<i>16</i>
<i>Figure 12: Gateway’s wireless network</i>	<i>17</i>
<i>Figure 13: Login page</i>	<i>17</i>
<i>Figure 15: Network Connection Settings.....</i>	<i>18</i>
<i>Figure 16: Devices Status page</i>	<i>19</i>
<i>Figure 17: Device Settings</i>	<i>19</i>
<i>Figure 18: Gateway Status.....</i>	<i>20</i>
<i>Figure 19: System configuration</i>	<i>20</i>

Figure 20: IO board test	21
Figure 21: Port configuration for testing	21
Figure 22: Successful testing of 'RS485_1' port and RTC.....	22
Figure 23: Module scanning process for a double-row layout.	24
Figure 24: Walking direction for a single-row module layout.....	26
Figure 25: Highlighted duplicate entries.....	26
Figure 26: PlantView file example	27

List of Tables

Table 1: String Reader LED status and indications.....	11
Table 2: RJ45 to RS485 wire assignment	13
Table 3: Gateway LED status and indications	15

Foreword

Please read this manual carefully before installing the Individual Module Monitoring (hereinafter: IMM) system.

This manual serves as a support for the installation of the IMM Monitoring System for photovoltaic plants which allows a module-level monitoring of the plant. Section 1 includes an overview of the IMM System and its individual components.

The manual describes the procedure after the modules have been installed, describing each step from the installation of the IMM hardware to the final completion of the plant in the Web Portal.

Please note that non-compliance to the instructions, especially the warning notes, can lead to irreparable hardware damages. These damages are not covered by the warranty.

Should you have any question, please don't hesitate to contact the AEG IMM / Sunsniffer Team.

How IMM Works

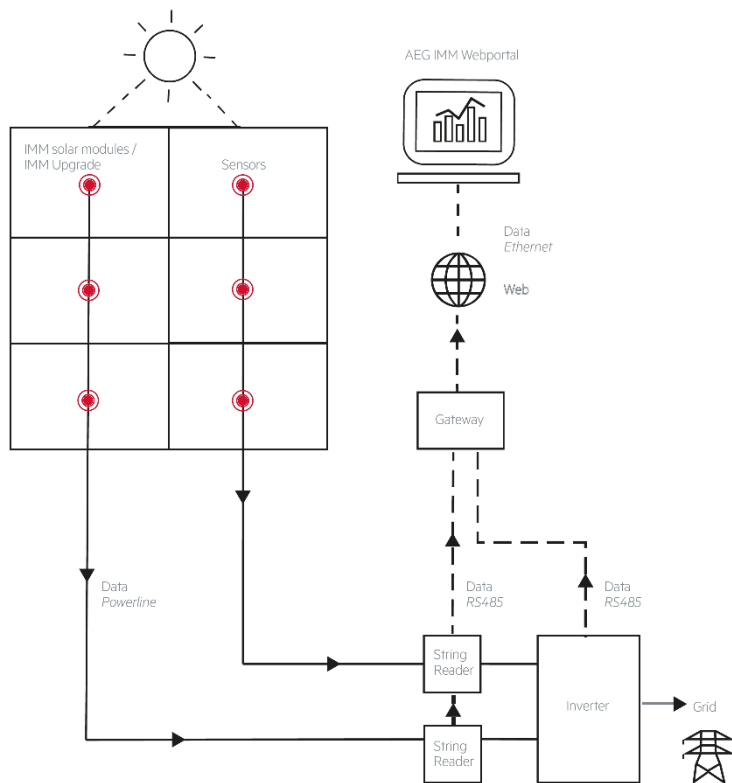

1 - Irradiated by sunshine, the AEG solar modules with integrated IMM Technology/the existing solar modules with IMM Upgrade produce clean energy.

5

2- The IMM Sensors within the IMM junction box/within the IMM Upgrade measure the voltage of each module and the temperature of each junction box.

3- The data from the IMM Sensors are sent to the String Reader via Smart Powerline communication (existing DC cabling)

4- The String Reader measures voltage, current, and have a built-in energy meter. When the Gateway requests the measurements, String Readers will send these measurements as well as the collected IMM Sensors' data.

5- The data gathered by the Gateway is then sent via internet to the Web Portal.

Installation workflow

The installation can be divided into 3 parts:

Hardware installation (1, 2); Configuration (3, 4); Plant creation in the Web Portal (5, 6, 7).

1

Starting point:
You have already installed your AEG solar modules with embedded IMM
(or retrofitted existing solar modules with IMM Upgrade)

2

Install String Readers and Gateway.

(see chapter 1.3-1.4 and Checklist on page 35)

3

Configure the Gateway

(see chapter 2 and Checklists on page 35)

AEG

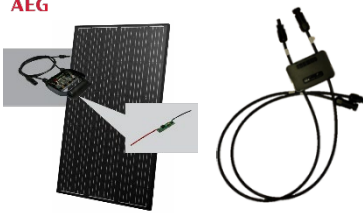

4

Scan the module serial numbers and fill in the forms (see chapter 3 and the section Templates/Annexes).

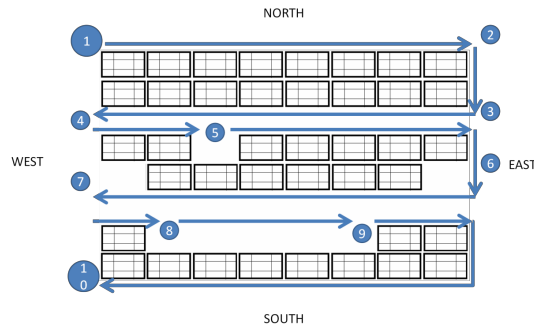

AEG

PLANT PROPERTIES

PLANT name	
Location	
All the below information are compulsory for a correct functioning of the SunSniffer Webportal	
Photo-voltaic	
Inverter	
Subarray	
Capacity	
Power	
Manufacturer	
New Technology	
Grid	
Grid Type	
Grid Voltage	
Grid Frequency	
Grid Phase	
Grid Protection	
Grid Protection	
Grid Protection	

6

5

Contact the AEG IMM / Sunsniffer support team to obtain login credentials for the Web Portal

6

Log in the Web Portal. Use the templates and the Plant Creation Wizard to create your plant in the portal.

7

Log in the Web Portal and start monitoring your plant



AEG

PLANT PROPERTIES

PLANT name	
Location	
All the below information are compulsory for a correct functioning of the SunSniffer Webportal	
Photo-voltaic	
Inverter	
Subarray	
Capacity	
Power	
Manufacturer	
New Technology	
Grid	
Grid Type	
Grid Voltage	
Grid Frequency	
Grid Phase	
Grid Protection	
Grid Protection	
Grid Protection	



What will I need?

Item	You will need it for...
Manual printout	...following the installation process and filling in the templates. See Section 4
Internet connection	...receiving data from the plant, configuring the Web Portal
Waterproof installation box, RS485 cables and tools	...installing the String Readers and Gateway
High resolution barcode scanner	...creating the Plant View. The Plant View creation requires the serial numbers of the modules and their spatial location. You can create the Plant View either be by manually inserting the serial numbers in an Excel sheet, or (more conveniently) by using a high-resolution barcode scanner. See section 3
230V AC outlet	...plugging in the power supply unit of the Gateway. The Gateway needs a constant power supply.
Laptop PC, Ethernet cables (and/or Ethernet switch)	...configuring the Gateway. Besides the laptop and Ethernet cable, use an Ethernet switch if your router has only one port.
Login credentials for the Web Portal	...accessing your IMM monitoring functionalities. You will receive these from the Susniffer/AEG IMM Support Team

1. Hardware Installation

7

1.1 IMM System Components

The IMM Monitoring System consists of sensors, String Readers and Gateways.

1.1.1 The IMM Sensor

AEG solar modules with integrated IMM Technology: In AEG solar modules with integrated IMM Technology, the IMM sensor is directly integrated by the manufacturer into the junction box of the module. The measured data, voltage, and temperature, combined with the module's serial number, are sent from the sensor to the String Reader through solar power cables. Measurements are transmitted every 30 seconds with an accuracy of +/- 1%.



Figure 1: Sensor

AEG IMM Upgrade: The IMM Sensors can also be retrofitted to existing plants / existing solar modules via the IMM Upgrade box (see Figure 2). The IMM Upgrade is connected in parallel to the module's junction box. The short cables are directly connected to the junction box and the longer cables connect to neighboring modules through MC4 connectors. The IMM Upgrade has to be mounted onto the back of the module. A suggested fitting of the IMM Upgrade is shown in Figure 2.



Note: Make sure to use only **the tape included** to stick the IMM Upgrade box directly on the back of the module as the module's temperature rises.

Note: It is crucial to note down the IMM Upgrade's serial number, the serial number of the retrofitted modules, and the related matching. (assignment). This is best done by scanning the module's serial number first, and then scanning the serial number of the IMM Upgrade connected to it.

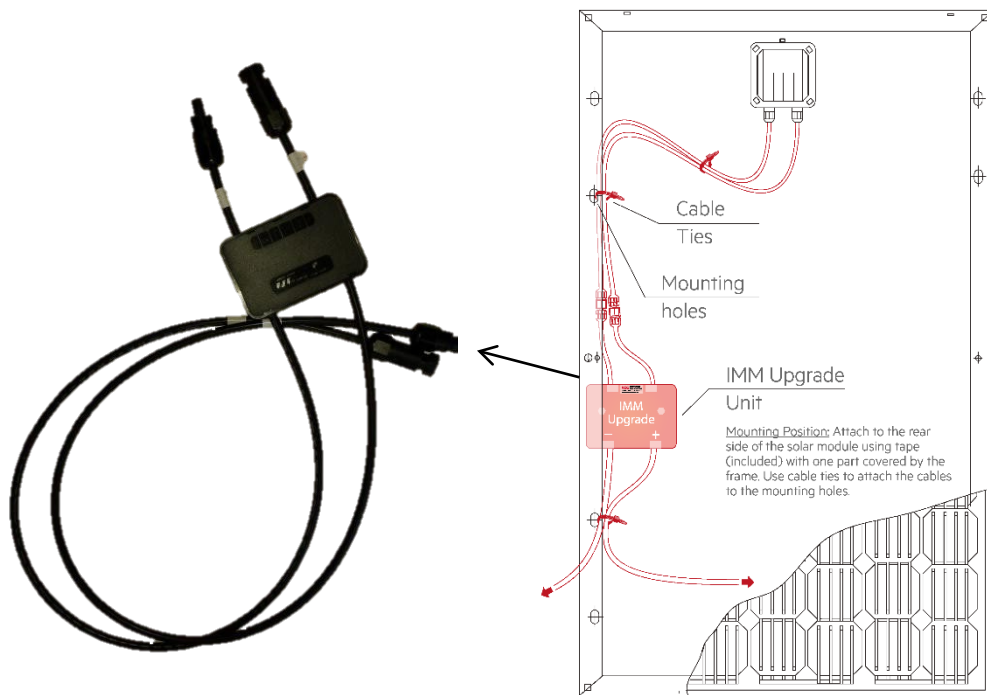

Figure 2: Connecting an IMM-Upgrade to a module

1.1.2 AEG IMM String Reader

String Reader: The String Reader is a device connected to the end of a solar string. It measures string current and string voltage, gathers measurements transmitted from the sensors in the string, and sends them to the Gateway.



Figure 3: AEG IMM String Reader

1.1.3 AEG IMM Gateway (S or L)

The Gateway gathers data from the field and sends them to the IMM / SunSniffer Web Portal (hereinafter: Web Portal).



Figure 4: AEG IMM Gateway

1.2. Connection Overview

Hardware installation includes String-Readers, Gateways, and additional devices to be connected to the Gateway. The corresponding wiring is shown in Figure 5. The red arrows represent DC lines, whereas the black arrows represent data lines.

If the IMM System is to be connected to an already existing plant, the installation of the IMM Upgrade boxes is required, in which the sensor is integrated.

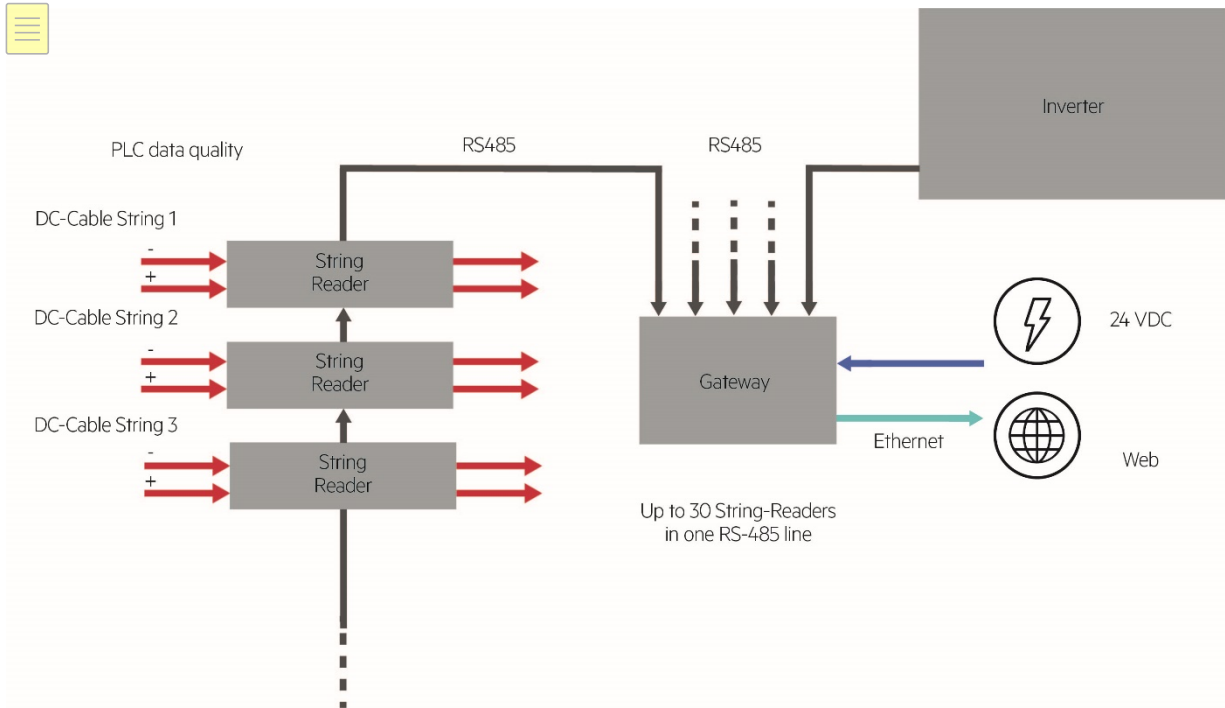

Figure 5: Schematic representation of the AEG IMM Monitoring System

1.3. String Reader Installation

1.3.1. String Reader Ports and Connections

The String Reader has connections for solar power cables and data communication cables. These are labelled in Figure 6.

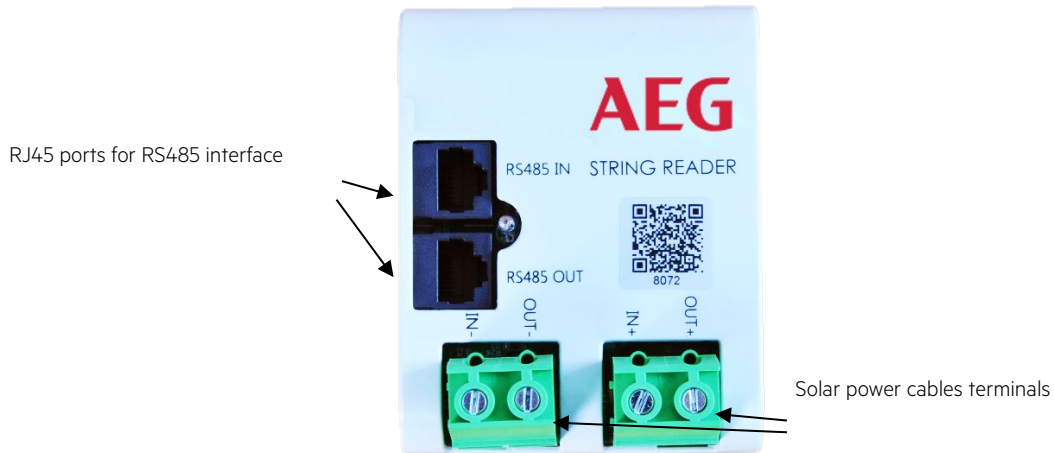

Figure 6: AEG IMM String Reader

The labels on the screw terminal blocks for solar cables are as follows:

- IN - = Negative cable from the solar string
- IN + = Positive cable from the solar string
- OUT - = Negative cable to solar inverter
- OUT+ = Positive cable to solar inverter

1.3.2. String Reader LED Indications

Table 1: String Reader LED status and indications

Status	Indication	
On	●	Device powered on and communication is established with Gateway
Blinking	◐	Device powered on but no communication with Gateway
Off	○	Device off

1.3.3. String Reader Installation

1. Make sure to note down every String Reader serial number and the solar string to which it will be connected. This information will be needed later on for the plant creation on the Web Portal. A template which can be used to fill out the necessary information can be found in Attachment A2 .

2. Choose a place to mount the String Reader. An ideal place would be close to the inverters, as all the cabling leads there.

3. Connect the solar power cables to the String Reader according to Figure 6. Make sure the connections to the String Readers have the correct polarity.

4. For data communication with the Gateway, the String Readers can be connected in RS485 buses in a multidrop connection as shown in Figure 7.



Figure 7: Multidrop connection of String Readers using RJ45 connectors



Note: Make sure to use straight-through (i.e. the colors at each end are wired in the same order) Cat-5e cables for the RJ45 ports.

The data cabling connection from the RJ45 ports of the Gateway to the first String Reader in the data bus should go to the 'RS 485 IN' port of the String Reader. Connection to the next String Reader goes from 'RS485 OUT' of the first device to 'RS485 IN' of the next device.

1.3.4. RJ45 Connector Wiring Sequence

The following diagram illustrates the functionality of each wire in the RJ45 connector.

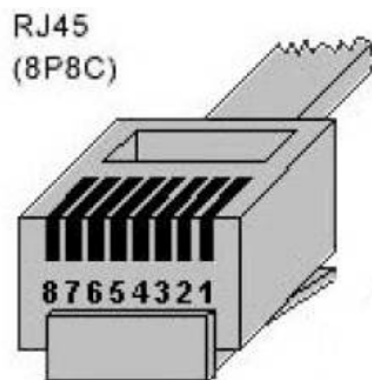

Figure 8 RJ45 connector

Table 2: RJ45 to RS485 wire assignment.

Pin Number	Color	Function
1	Orange-White	N/A
2	Orange	N/A
3	Green-White	RS485-A signal (+)
4	Blue	Ground
5	Blue-White	Ground
6	Green	RS485-B signal (-)
7	Brown-White	Power (+24V)
8	Brown	Power (+24V)



Note: Although RS485 standard has a maximum distance limitation of 1000m for data communication, the +24V power supply from the Gateway to the String Readers can be affected at such distances. Therefore, it should be ensured that enough power is reaching the devices in the RS485 bus at long distances.

1.4. Gateway

Before installing a Gateway, the following information should be noted down correctly for set-up of the Gateway on the Web Portal:

1. **Serial Number:** found on the Gateway housing (Example: 7.2.002253)
2. **ID:** it is the last four digits of the serial number (Example: 2253)
3. **Revision:** it is mentioned on the box in which the Gateway was shipped (Example: CB DIN-A)

1.4.1. Gateway Ports

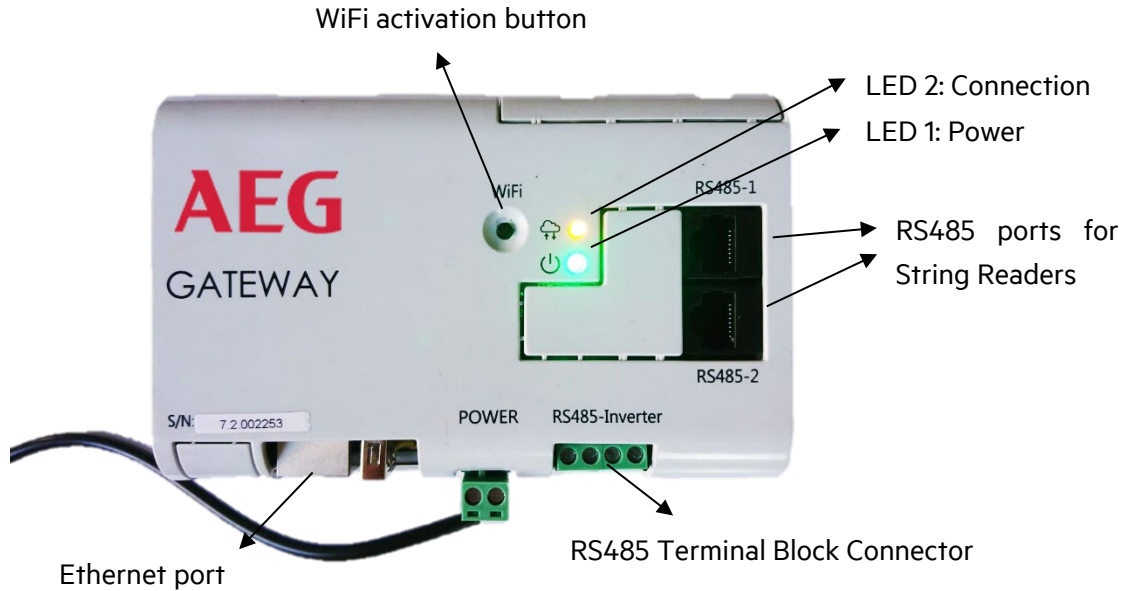









Figure 9: AEG IMM Gateway ports and connections

1.4.2. Gateway LED status and indication

Table 3: Gateway LED status and indications



LED	Status	Indication
1 	Constantly on 	Gateway is powered on
	Off 	Gateway is powered off
2 	0.5 sec on / 0.5 sec off 	No Internet Connection
	0.5 sec on / 3.5 sec off 	Connection is established
	2 sec on / 2 sec off 	WiFi is activated
	Constantly on 	Gateway is still booting up

1.4.3. Gateway installation

1.Connect String Reader RS485 buses to any of the RJ45 ports of the Gateway as shown in Figure 7.

	<p>Note: The number of String Readers that can be connected to the Gateway is limited by the Gateway's type. IMM Gateway S can connect to a total of 5 String Readers, whereas IMM Gateway L can connect to a total of 30 String Readers.</p>
---	--

2.Inverter bus can be connected to the screw terminal block 'RS485-Inverter'. This port has adjustable baudrate in the range of 1200-115200 which can be set according to connected devices.

	<p>Warning: the terminal block has a 4-wire input as shown in Figure 10. However, only 'A', 'B' and 'GND' are utilized. The '+24V' input should not be used for an inverter data bus, otherwise connected devices might get damaged. The '+24V' should only be used if String Readers bus is to be connected to this port.</p>
	<p>Note: Some inverters and other devices that use RS485 interface for communication have the labels '+' and '-' instead of 'A' and 'B' respectively. So care should be taken when connecting such devices.</p>

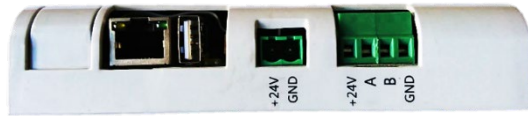

Figure 10 Side view of the Gateway showing the RS485 Inverter connector

3. Plug in the Ethernet cable from the router to the Gateway.
 4. Connect the power supply to the Gateway. Pay attention to polarity, otherwise the device will be damaged.
- Note: The Gateway takes up to 2 and a half minutes to fully boot up.
5. The Gateway is now installed and ready to be configured from its webUI as detailed in Section 2.



Note: After installing the system, each module needs to be scanned before leaving the plant site to be used later in plant creation (see Section 3.1).

2.Configuration

After the Gateway is installed and all devices are connected to it, it should be configured accordingly in order to correctly detect and gather data from the devices. This can be done through the Gateway's webUI.

16

2.1. Gateway's webUI

The webUI is a user interface through which the Gateway's configuration can be changed. Configuration options include network settings and RS485 ports.



Figure 7: Gateway's webUI page

2.1.1. Accessing the Gateway's webUI

1. Press on the WiFi button on the Gateway. LED 2 blinking behavior should change, indicating that WiFi access point is activated.
2. Click on the Network icon on the taskbar of your laptop and click on the network that begins with SunSniffer and connect to it. Repeat step 1 if it doesn't show up.

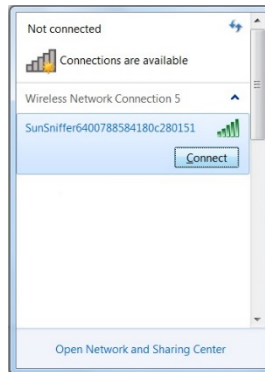

Figure 8: Gateway's wireless network

3. Connect to this wireless network. Enter the password "SunSnifferpass" and click on "OK".
4. After the connection is established, the Gateway's webUI can be accessed by typing in '192.168.12.1' to the address bar of any web browser. Login by typing "admin" in both the username and password fields.

17

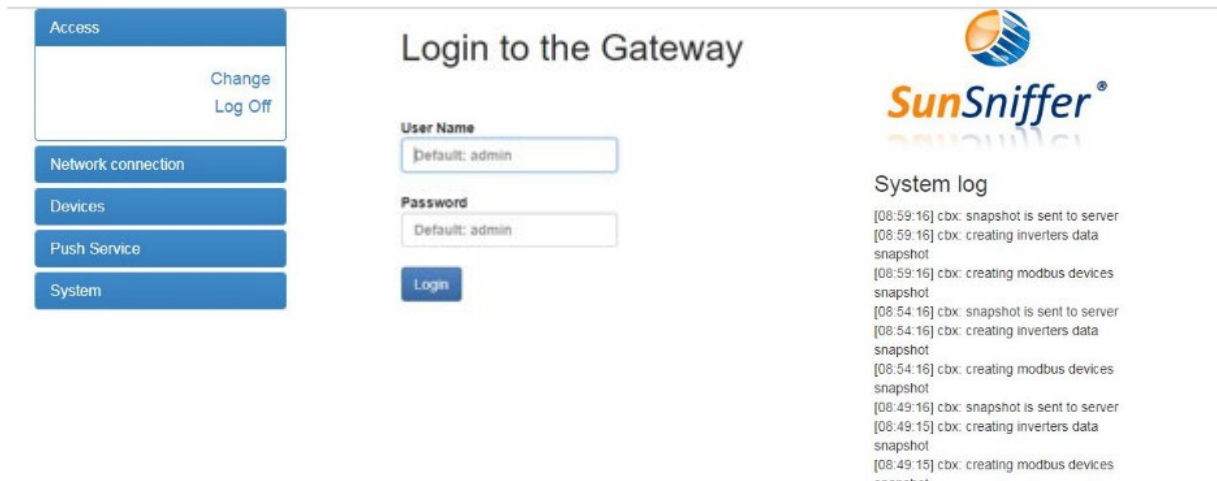

Figure 9: Login page

5. After a successful login, you will be redirected to 'Change Login Data' page, where login credentials can be changed.



Notes regarding the Gateway's WiFi AP:

-The WiFi AP stays active for one hour after pressing the button. To reactivate it, simply press again on the WiFi button.

-If the Gateway is online while connecting to it through WiFi, it will act as a hotspot and also provide internet access to any laptop or PC connected to it.

2.2. Network Connection

Network settings can be changed from the 'Network Connection Settings' page.

Figure 10: Network Connection Settings

To assign a local IP address to the Gateway manually, uncheck the box next to 'DHCP' and type in the required IP settings in the field below. Proxy settings can also be applied by checking the box next to 'Proxy'.

2.3. Devices

The 'Devices' tab is used to configure the devices connected to the Gateway via its RS485 ports. The 'Devices Status' page shows the number and type of devices connected to the Gateway's RS485 ports.

Type	Baudrate	Devices
RS485-Inverter	9600	
RS485_1	9600	1 (View)
RS485_2	9600	

Position	ID	Voltage	Current	Sensors
1	7301	-	-	-

Figure 11: Devices Status page.

The 'Devices Status' page will initially show no devices, even if there actually *are* devices connected to the Gateway. To detect connected devices, the RS485 ports should be scanned from the 'Device Settings' page.

Check the 'Scan' option for occupied ports and select the type of connected device from the drop-down list. The Baudrate for 'RS485-Inverter' can be changed according to the connected inverter type. After clicking on 'Apply', the Gateway will start scanning the ports for connected devices. This process can be monitored from the System log on the right side of the page.

Port	Baudrate	Type	Scan
RS485-Inverter:	9600	none	<input type="checkbox"/>
RS485_1:	9600	String Reader	<input checked="" type="checkbox"/>
RS485_2:	9600	none	<input type="checkbox"/>

Figure 12: Device Settings

2.4. Push Service

This service enables sending SunSniffer® data to a FTP server. For further information, please contact SunSniffer GmbH & Co. KG.

2.5. System

This tab shows the Gateway status, allows the user to send commands to the Gateway, and to test the RJ45 communication ports.

Gateway Status

Connection Status: online
Connection speed: 100Mb/s
Sendings interval (sec): 200
Serial number: 7.2.002282
ID: 2282
Firmware: v. 3

System log

```

[15:59:29] cbx: total devices found: 1
[15:59:29] cbx: scan complete
[15:59:28] cbx: slaveID 1: 1-String C
[15:59:26] cbx: performing scan on bus 127.0.0.1:10002
[15:59:25] cbx: assigning 7301 to id 1
[15:59:25] cbx: this bus supports auto id assignment
[15:59:19] cbx: querying serials at 127.0.0.1:10002
    
```

Figure 13: Gateway Status

The commands that can be sent to the Gateway are shown in Figure 19. ‘Download Settings’ allows the user to download the current configuration of the Gateway in the form of a JSON file. This can be later uploaded using ‘Upload Settings’ to apply all the settings in case the Gateway is replaced with another one.

20

System configuration

Set Port Scan:
 Restart Gateway:
 Download Settings:
 Upload Settings:

System log

```

[15:59:29] cbx: total devices found: 1
[15:59:29] cbx: scan complete
[15:59:28] cbx: slaveID 1: 1-String C
[15:59:26] cbx: performing scan on bus 127.0.0.1:10002
[15:59:25] cbx: assigning 7301 to id 1
[15:59:25] cbx: this bus supports auto id assignment
[15:59:19] cbx: querying serials at
    
```

Figure 14: System configuration

The ‘IO board test’ page allows the user to test the four communication ports ‘RS485-1’, ‘RS485-2’, ‘RS485-3’, and ‘RS485-4’, as well as the Gateway clock.

- Access
- Network connection
- Devices
- Push Service
- System
 - Status
 - Configuration
 - Device Settings
 - [IO board test](#)

Read/Write	RS485_1	RS485_2
Inverter port (RS485_5)	NO DATA	NO DATA

Real Time Clock (RTC)
 NO DATA

Start test



System log

```

[15:59:29] cbx: total devices found: 1
[15:59:29] cbx: scan complete
[15:59:28] cbx: slaveID 1: 1-String C
[15:59:26] cbx: performing scan on bus 127.0.0.1:10002
[15:59:25] cbx: assigning 7301 to id 1
[15:59:25] cbx: this bus supports auto id assignment
[15:59:19] cbx: quering serials at 127.0.0.1:10002
[15:59:16] cbx: Total inverters found: 0
[15:59:16] cbx: Inverters scan complete
                    
```

Figure 15: IO board test

In order to initiate the testing, the port to be tested should be connected to 'RS485-Inverter' port in the manner shown in Figure 21.



Figure 16: Port configuration for testing

The result of a successful testing is as shown in Figure 22. The RTC option tests the Gateway's clock for time tracking.

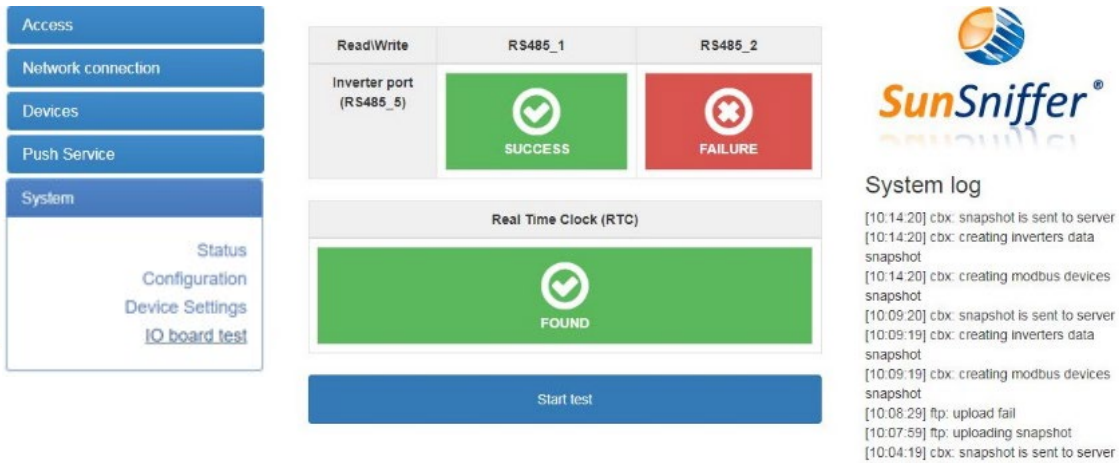

Figure 17: Successful testing of 'RS485_1' port and RTC

Each port can be tested once at a time. That's why when one of the ports is being tested, the other port will automatically fail the test.



Note: In order to prepare the connection between 'RS485-Inverter' and the other ports, refer to Table 2.

3. Preparation for Plant Creation

After having successfully finished hardware installation, the plant can be created and integrated to the Webportal. For this purpose, the following information is required.

1. Plant name.
2. Address including country, city, postal code and street.
3. Date of commission under the terms of the Renewable Energies Act.
4. Size of the plant in kWp, which is the product of module count and nominal module power.
5. Renewable energy feed-in tariff in €/kWh.
6. Target yield in kWh/kWp/yr.
7. Operating time/date of end of the assured feed-in compensation. Both finish dates refer to the 01.01 of the subsequent year of commissioning plus 20 years.

8. Module and inverter types (Manufacturer and model).
9. Monitoring level: Inverter, string, hybrid, or module.
10. Geolocation (longitude and latitude, height above the sea level).

Additionally, the following documents need to be prepared. Each document is explained in the following sections. **Example and template files can also be found in Section 6 “Appendices”.**

1. PlantView
2. Hardware plan
3. Module mapping
4. Retrofit mapping (in case the plant is retrofitted with SunSniffer)

3.1. PlantView

PlantView is a digital map of the PV plant that enables exact localization of every single module. The serial numbers of every module in the plant are placed in an Excel sheet in the same pattern as they are in the plant. The PlantView can be prepared either manually by copying the serial numbers to the Excel sheet, or automatically by using “Module Scan”, which is a process where module serial numbers are scanned in a specific way to generate an Excel sheet with the module serial numbers arranged in the same pattern as they are on-site using Excel macros.

3.1.1. Module Scan

To run the module scan, a scanner that is capable of storing scans vertically in a text file is needed. [ARGOX PT-20](#) or [Zebra TC20](#) are examples of scanners that can be used. Furthermore, the barcode sheet (see Section 6 “Barcode sheet for module scan” is required, which contains barcodes used to set parameters such as walking direction, module gaps etc.

The following section describes how module scan is performed.

3.1.2. Scan order

The first module you have to start scanning from is the module which is situated in the northwestern direction (in viewing direction on the module front it is the module back left).

Start the module scan by scanning the „**Start**“ code in the barcode sheet. To scan a modules row, the walking direction should be set in order to assign the module order correctly. Going in eastern direction means going right on the module plan and going in the western direction means going left.

If the module row is completely scanned, the code “**End Row**“ should be scanned to indicate that the entire row is scanned. Next, either an empty row can be added through “**Row Gap**“ code, or another row is directly scanned by specifying the walking direction with the codes “**Right**“ or “**Left**“.

If the row itself has gaps, “**Module Gap**” code should be scanned, which initiates the presence of a gap in the row. Then the gap length can be defined via the number codes “1”, “2”, “4”, “8” and “16”. Gaps that are bigger can be input by summing up the numbers scanned.

Example: Submitting a gap of 7 modules via scanning the codes:

” Module Gap “→” 1 “→” 2 “→” 4 “ ” represent a gap length 7 (1+2+4)

Inputting a gap of 13 modules via scanning the codes:

” Module Gap “→” 1 “→” 4 “→” 8 “ ” represent a gap length of 13 (1+4+8)

After inputting the gap length, the scanning process can be continued. When all rows and modules of the plant have been scanned, “Stop” code must be scanned to finish the module scan. The scanned serial numbers of the modules are stored in the scanner and now need to be transferred to the PC. The following examples help to understand the procedure better.

Example: Double-rowed module layout

The following procedures describe the module scanning process for the double-rowed module layout shown in Figure 23.

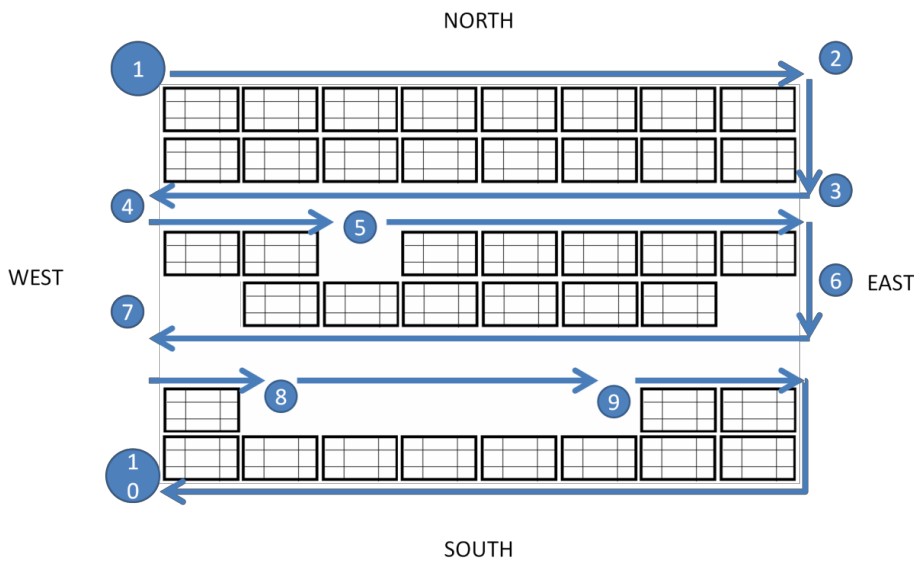

Figure 18: Module scanning process for a double-row layout.

1.The start is at the northwestern module (module at the top left). Scan the “**Start**” code to begin with the module scan, then the “**Right**” code to set walking direction. Scan the serial number barcodes of the modules (sticker under the glass of the modules) in the first upper row.

2. To finish the row, scan the „**End Row**“ code.
3. Add the next row directly by setting the walking direction with the code „**Left**“. Scan the serial numbers of the modules (the lower of the double-row) one after another.
4. Finish the series with „**End Row**“ again. Now there is an empty space till the next double row. This is inserted with the code „**Row Gap**“. Then start the next series with the walking direction „**Right**“ again.
5. Scan the modules' serial numbers till you reach the gap. Since one module is missing here, the gap has a length of 1. Scan the code „**Module Gap**“ to make a gap. Then scan the code „**Gap 1**“ to insert a gap of length 1. After that, the scan of the modules' serial numbers can be continued just like before.
6. End the row and start the new one by initiating the walking direction. The missing module can be submitted via scanning „**Module Gap**“ and „**Gap 1**“ codes.
7. A gap at the end of a row is also detected via the „**Module Gap**“ and „**Gap 1**“ codes.



Note: Gaps at the beginning and end of a row must also be inserted.

8. After inserting the gap, end the row and then add an empty row with the code „**Row Gap**“, and start the next row by setting the walking direction.
9. Initiate the gap by scanning „**Module Gap**“ code. Then scan the codes „**Gap 1**“ and „**Gap 4**“ to insert a gap of 5 modules. After the gap is input, the scan can be continued as usual.
10. After scanning the last row and finishing with „**End Row**“, the module scan is terminated by scanning the code „**Stop**“.

In principle the procedure is the same as single-rowed module constructions; further, please make sure that a row gap should be inserted between the module rows using the code „**Row Gap**“. The recommended walking direction is shown in Figure 24.

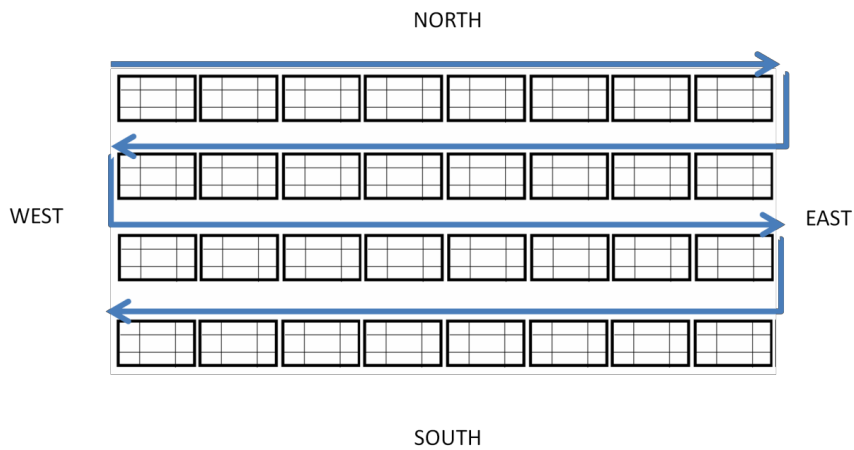

Figure 19: Walking direction for a single-row module layout.

3.1.3. PlantView Preparation from Module Scans

Now the module plan can be created from the obtained scans by following these instructions:

1. Transfer the scans from the scanner to a computer, and export them to the file 'Plantview.xlsm', which can be obtained from the Webportal by navigating to "Monitoring & Analysis" → "Plant View & Layout" and clicking on "Upload XLS". The scans should be placed in Table 1 of the file vertically starting from cell A1.
2. Use 'Conditional Formatting' → 'Highlight Cells Rules' → 'Duplicate Values...' to check for modules which got scanned twice. Delete any duplicates.

18	SEGP6-60A212080151210	
19	Lücke	
20	Zahl 2	
21	SEGP6-60A212080152012	
22	SEGP6-60A212080151966	
23	SEGP6-60A212080151701	
24	SEGP6-60A212080152013	
25	SEGP6-60A212080152033	
26	SEGP6-60A212080152011	
27	SEGP6-60A212080152087	
28	SEGP6-60A212080152087	
29	SEGP6-60A212080150826	
30	SEGP6-60A212080150807	
31	Lücke	
32	Zahl 1	
33	SEGP6-60A212080151181	
34	SEGP6-60A212080151151	
35	SEGP6-60A212080151138	
36	SEGP6-60A212080150812	
37	SEGP6-60A212080151135	
38	SEGP6-60A212080150854	
39	SEGP6-60A212080150840	
40	Lücke	

Figure 20: Highlighted duplicate entries

3.4. Retrofit Mapping

This file is needed in case the plant is retrofitted with Retrofit-Boxes. It should contain a list of Retrofit-Box serial numbers and modules serial numbers, to which the Retrofit-Boxes are connected. This document is extremely important in order to assign the retrofitted sensors to their correct modules. A sample file can be downloaded from the Web Portal from “Hardware Manager” -> “Hardware Settings”, and clicking on “Download example file” next to “Retrofit mapping”. The sample file can be seen in Attachment 5.

4. Plant Creation

The plant is now fully configured and ready to be created on the Web Portal.

Follow the video and the Plant Creation wizard to create your plant in the portal. Should you need further assistance, please contact our team.

5. Contacts

For further assistance or enquiries, please contact Solar Solutions or the SunSniffer Support.

28

Solar Solutions GmbH

Schneckenhofstrasse 19

60596 Frankfurt am Main, Germany

Phone: +49 (0) 69 400 500 810

Web: www.aeg-industrialsolar.de

E-Mail: imm-support@aeg-industrialsolar.de

6. Appendices

Barcode sheet for module scan

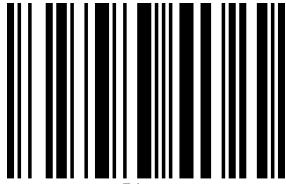

Stop

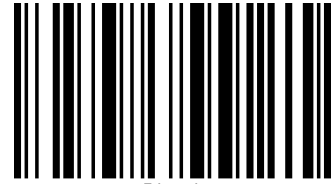

Start



Left

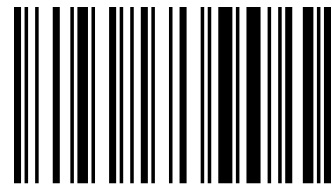

Right

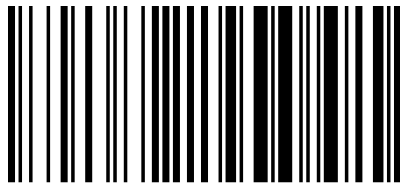

End Row

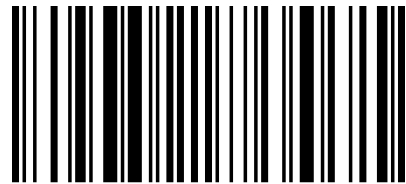

Row Gap

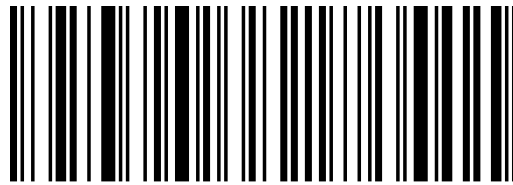

Module Gap

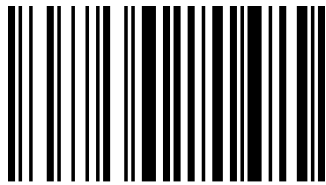

Gap 1



Gap 2

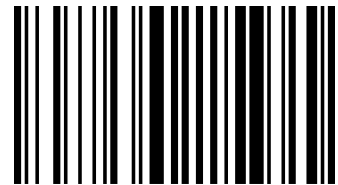

Gap 4

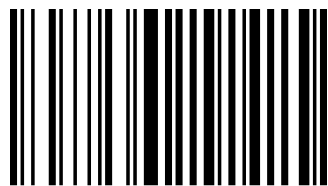

Gap 8

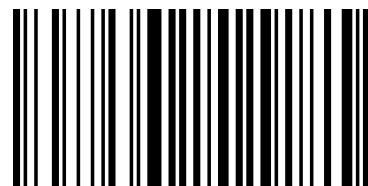

Gap 16



PLANT PROPERTIES

PV-plant	
Date	
Editor	

All the below information are compulsory for a correct fonctionment of the SunSniffer Webportal

Plant name	
Address	
Country	
City	
Postcode	
Street	
General Settings	
Plant Size (kWp)	
Currency	
Tariff start (YYYY/MM/DD)	
Feed-in Tariff per kWh	
Tariff end (YYYY/MM/DD)	
Module Manufacturer	
Module Model	
Plant Estimated Lifetime	
Target kWh/kWp/yr.	

A2 String/String Reader/Inverter assignment sheet (Hardware Plan)



ASSIGNMENT OF STRINGS, STRING READERS, AND INVERTERS

Date	
Editor	

String nr.	String Reader ID (4-digit)	Inverter Serial Number	Inverter Input Number	MPPT	Gateway ID (4 - digit)	Gateway Port Number	Device Type (String Reader / Inverter)
1	6589	LVB164930	1	A	2253	2	String Reader
2	6785	LVB164930	2	B	2253	2	String Reader
3		LVB164930			2253	5	Inverter
4	6584	MNX2567	1	A	2253	2	String Reader
5	5458	MNX2567	2	A	2253	2	String Reader
6		MNX2567			2253	5	Inverter
7							
8							
9							
10							
11							
12							
13							
14							
15							
16							
17							
18							

1

String Reader ID (4-digit)	Inverter Serial Number	Inverter Input Number	MPPT	Gateway ID (4 -digit)	Gateway Port Number	Device Type (String Reader / Inverter)
----------------------------	------------------------	-----------------------	------	-----------------------	---------------------	--

A3 String Reader – Module Mapping



STRING READER - MODULE MAPPING

PV-plant	
Date	
Editor	

Please fill in the "Mapping" tab as follows:

- 1) In each blue cell below please input the String Reader identification number (ID) for each String Reader deployed in your plant. Add as many columns as the number of the String Readers deployed.
- 2) In the column below each String Reader ID, please list the serial numbers of the modules that are respectively connected to each String Reader. Add as many cells as the number of modules belonging to each string.

Example (with strings of different lengths)

String 1	String 2	String 3	String 4
String Reader ID	String Reader ID	String Reader ID	String Reader ID
Module 1 SN	Module 1 SN	Module 1 SN	Module 1 SN
Module 2 SN	Module 2 SN	Module 2 SN	Module 2 SN
Module 3 SN	Module 3 SN	Module 3 SN	Module 3 SN
Module 4 SN	Module 4 SN	Module 4 SN	Module 4 SN
Module 5 SN	Module 5 SN	Module 5 SN	Module 5 SN
Module 6 SN	Module 6 SN	Module 6 SN	Module 6 SN
Module 7 SN	Module 7 SN	Module 7 SN	Module 7 SN
Module 8 SN	Module 8 SN	Module 8 SN	Module 8 SN
Module 9 SN	Module 9 SN		
Module 10 SN	Module 10 SN		

String Reader 1 ID	String Reader 2 ID	String Reader 3 ID
Module 1 SN	Module 1 SN	Module 1 SN
Module 2 SN	Module 2 SN	Module 2 SN
Module 3 SN	Module 3 SN	Module 3 SN

A4 PlantView Example



PLANTVIEW FILE

Plantview is the physical representation of the arrangement of the modules in the installation. Below are some examples based on different monitoring levels.

String-level Monitoring:

When monitoring on **String Level**, the modules should be represented according to their approximate location using the String Reader ID that the modules are connected to. Inverters are represented by their serial number.

StringReader_ID 1	StringReader_ID 1	StringReader_ID 1	StringReader_ID 1	StringReader_ID 1	StringReader_ID 1	StringReader_ID 1	StringReader_ID 1	StringReader_ID 1	StringReader_ID 1	StringReader_ID 1
StringReader_ID 1	StringReader_ID 1	StringReader_ID 1	StringReader_ID 1	StringReader_ID 1	StringReader_ID 1	StringReader_ID 1	StringReader_ID 1	StringReader_ID 1	StringReader_ID 1	StringReader_ID 1
StringReader_ID 2	StringReader_ID 2	StringReader_ID 2	StringReader_ID 2	StringReader_ID 2	StringReader_ID 2	StringReader_ID 2	StringReader_ID 2	StringReader_ID 2	StringReader_ID 2	StringReader_ID 2
StringReader_ID 2	StringReader_ID 2	StringReader_ID 2	StringReader_ID 2	StringReader_ID 2	StringReader_ID 2	StringReader_ID 2	StringReader_ID 2	StringReader_ID 2	StringReader_ID 2	StringReader_ID 2
StringReader_ID 3	StringReader_ID 3	StringReader_ID 3	StringReader_ID 3	StringReader_ID 3	StringReader_ID 3	StringReader_ID 3	StringReader_ID 3	StringReader_ID 3	StringReader_ID 3	StringReader_ID 3
StringReader_ID 3	StringReader_ID 3	StringReader_ID 3	StringReader_ID 3	StringReader_ID 3	StringReader_ID 3	StringReader_ID 3	StringReader_ID 3	StringReader_ID 3	StringReader_ID 3	StringReader_ID 3

Inverter_SN 1

A5 Retrofit box / Module Mapping (Retrofit Mapping)



RETROFIT BOX - MODULE SERIAL NUMBER MAPPING

PV-plant	
Date	
Editor	

Please fill in the the excel file as follows:

- 1) In column "A" please input the Retrofit Boxes' serial numbers.
- 2) In column "B" please input the Modules' serial numbers.
- 3)The text in row 1 should be deleted.

Example

<i>Retrofit Box Serial Number</i>	<i>Module Serial Number</i>
Retrofit 1 SN	Module 1 SN
Retrofit 2 SN	Module 2 SN
Retrofit 3 SN	Module 3 SN
Retrofit 4 SN	Module 4 SN
Retrofit 5 SN	Module 5 SN
Retrofit 6 SN	Module 6 SN
Retrofit 7 SN	Module 7 SN
Retrofit 8 SN	Module 8 SN
Retrofit 9 SN	Module 9 SN
Retrofit 10 SN	Module 10 SN

<i>Retrofit Box Serial Number</i>	<i>Module Serial Number</i>

Checklists

Checklist for the installation process

- Register String Readers in assignment list (appendix A.3)
- Insert String Readers in DC-cabling, pay attention to the right polarity
- Connect String Readers via RS-485-Data line in series (up to 30 pieces)
- Register the Gateway in the assignment list
- Connect String Readers via RS-485 to Gateway
- Connect Gateway via Ethernet cable with the router

Checklist to close the hardware installation

- To start the Gateway connect the power supply unit(s) to the power supply system
- Login in to Gateway browser interface and configure Gateway
- Check in the Webportal if the Gateway sends data
- Check the data sendings in the Webportal:
 - Number of String Readers
 - Measurements of electricity and voltage of the String Readers
 - Do the String Readers receive sensors?