

AEG

N-TYPE TOPCON HALF-CUT BIFACIAL MODULE

AS-M1 32 3W-BH(RM10)/HV

AS-M1 32 3Y-BH(RM10)/HV

CHARACTERISTICS

Power range: 615 -630 Wp

Double glass bifacial Photovoltaic Module

Half-Cut N-Type TOPCON cell technology

Efficiency up to 23.30 %

2.0 mm glass thickness

2 mm

ADVANTAGES

Extra converting surface on the module back thanks to bifaciality

Outstanding sleek optics

Extra long cables for greater installation flexibility

Extra power thanks to rectangular solar cells



**30 YEARS PRODUCT WARRANTY AND
30 YEARS PERFORMANCE WARRANTY
30 YEARS EXCHANGE AND REFUND SERVICE**



N-TYPE TOPCON BIFACIAL MODULE

AS-M1323W-BH(RM10)/HV | AS-M1323Y-BH(RM10)/HV

PRODUCT SERIES & NAMECODE (PNC)	
AEG HIGH EFFICIENCY ERIES	
AS-M1323W-BH(RM10)-615/620/625/630/HV, white back side pattern (glazed glass), silver frame	
AS-M1323Y-BH(RM10)-615/620/625/630/HV, white back side pattern (glazed glass), black frame	

CERTIFICATIONS	
System	ISO 9001, ISO 14001, ISO 45001
Product	IEC EN 61215-1:2016, IEC EN 61215-1:2016, IEC 61215-2:2016, EN 61215-2:2017, IEC 61730-1:2016 / EN IEC 61730-1:2016, IEC 61730-2:2016 / EN IEC 61730-2:2016

ELECTRICAL CHARACTERISTICS AT STC ^{1,2}					
Nominal Power (Pmax)	[Wp]	615	620	625	630
Power Sorting ³	[W]	0-5	0-5	0-5	0-5
Maximum Power Voltage (Vmp)	[V]	41.43	41.56	41.69	41.82
Maximum Power Current (Imp)	[A]	14.84	14.92	14.99	15.07
Open Circuit Voltage (Voc)	[V]	48.89	49.04	49.19	49.34
Short Circuit Current (Isc)	[A]	16.02	16.11	16.19	16.27
Module Efficiency (ηm)	[%]	22.8	23.0	23.1	23.3
Maximum System Voltage	[V]	1500	1500	1500	1500
Maximum Series Fuse	[A]	35	35	35	35

WARRANTIES		
Product warranty ⁶	[years]	30
Performance warranty (linear) ⁷	[years]	30

TEMPERATURE CHARACTERISTICS		
NMOT	[°C]	41 (±2)
Pmax Temp. Coefficient (γ)	[%/°C]	-0.29
Voc Temp. Coefficient (β)	[%/°C]	-0.25
Isc Temp. Coefficient (α)	[%/°C]	0.043
Operating temperature	[°C]	-40~+85

ELECTRICAL CHARACTERISTICS AT NMOT ⁴					
Maximum Power (Pmax)	[W]	462.5	466.2	470	473.8
Maximum Power Voltage (Vmp)	[V]	39.00	39.12	39.24	39.36
Maximum Power Current (Imp)	[A]	11.86	11.92	11.98	12.04
Open Circuit Voltage (Voc)	[V]	46.44	46.58	46.72	46.86
Short Circuit Current (Isc)	[A]	12.94	13.00	13.07	13.13

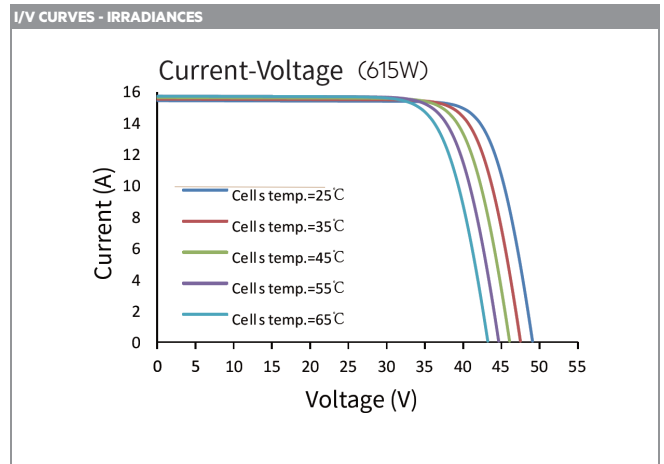

ELECTRICAL SPECIFICATIONS - INTEGRATED POWER / POWER GAIN ⁵					
Bifaciality factor		80±10%			
Pmpp Gain		10%	15%	20%	25%
Maximum Power (Pmax)	[W]	677	707	738	769
Maximum Power Voltage (Vmp)	[V]	46	48	50	52
Maximum Power Current (Imp)	[A]	16.	17	18	19
Open Circuit Voltage (Voc)	[V]	54	56	59	61
Short Circuit Current (Isc)	[A]	18	18	19	20

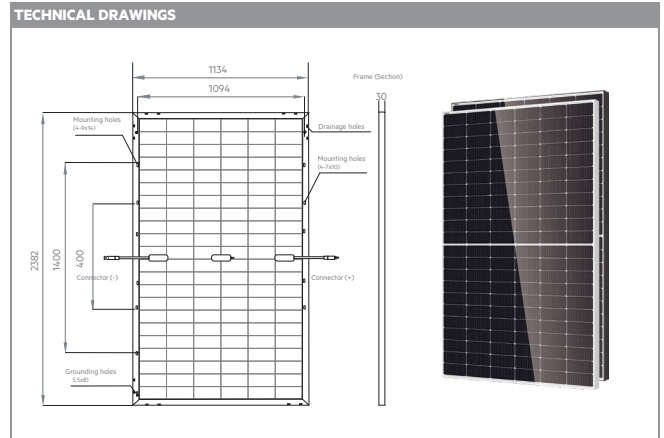

MECHANICAL CHARACTERISTICS		
Solar cells	monocrystalline [pcs]	132
	Dimensions [mm]	RM10 Bifacial Half-cut [182 x 199]
Front glass	high-transparency	
	Thickness [mm] / [in]	2 / 0.08
Back glass	White back side pattern (glazed)	2 / 0.08
Encapsulant	EVA	transparent
Frame	Anodized aluminum alloy	silver or black
Junction box	Split-type, IP68	
	Bypass diodes	3
UV-resistant cables	Length [mm] / [in]	1400/55.12
	Section [mm ²]	4
Connectors	MC4 Original	
Dimensions	H x L x W [mm]	2382 x 1134 x 30
	H x L x W [in]	93.78 x 44.65 x 1.18
Weight	[kg] / [lbs]	32.8 / 72.29
Maximum load	Wind / Snow [Pa]	2400 / 5400
Fire Class	Class A	

PACKAGING		
Packing configuration	[pcs/pallet]	36
Loading capacity	[pcs/40 ft container]	720

NOTES
1-Standard Test Conditions (STC): Irradiance 1000 W/m ² , Air Mass AM = 1.5, Cell Temperature 25°C
2-Measurement tolerances (IEC 61215:2016): Pmax±3.0%, Voc±3.0%, Isc±4.0%
3-AEG photovoltaic modules are classified according to a principle of positive power tolerance: the Power Output measured at STC of the delivered modules exceeds their assigned Nameplate Nominal Power
4-NMOT: Nominal module operating temperature, Irradiance 800 W/m ² , Wind Speed 1m/s; Ambient Temperature 20°C, Air Mass AM=1.5
5-Electrical characteristics with different rear power gain. Reference to 615 W
6-Full text of the Warranty Terms available at: www.aeg-solar.com
7-(HE/GG) No less than 99% of the minimum "Peak Power at STC" in the first year; power output decline no more than 0.4% per year thereafter, ending with 87.4%.
Dimensions in the technical picture are expressed in mm with tolerance ±2 mm (±0.079") / Version 2024.10.V2.EN © Solar Solutions Group. Specifications in this datasheet are subject to change without notice.
AEG is a registered trademark used under license from AB Electrolux (publ).

SOLAR SOLUTIONS AG

Riedweg 3 | 6418 Rothenthurm | Switzerland
www.aeg-solar.com | info@aeg-solar.com

AEG is a registered trademark used under license from AB Electrolux (publ)